

Junistar Eco

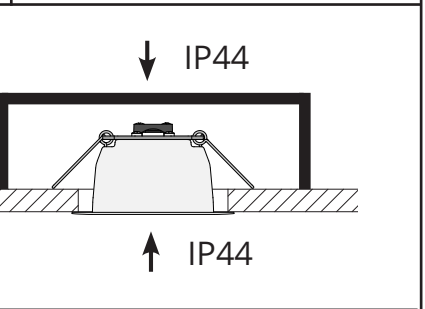

230V, 50/60Hz

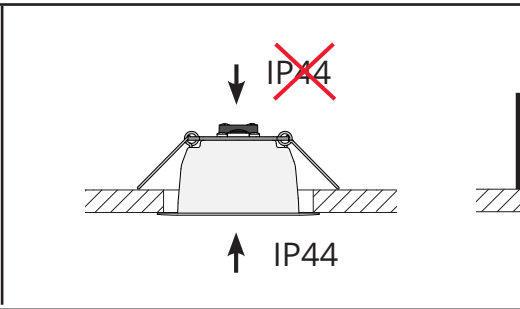
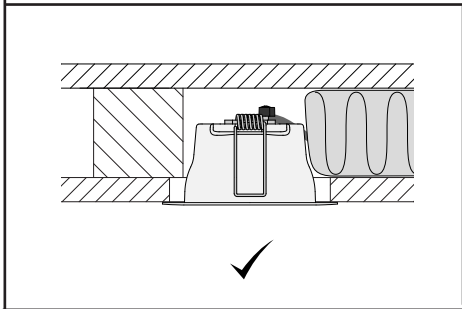
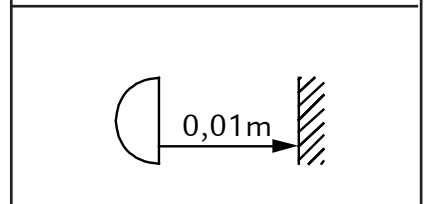
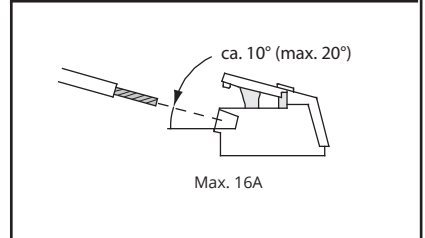
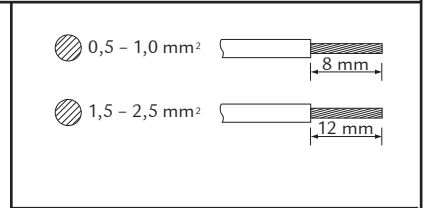
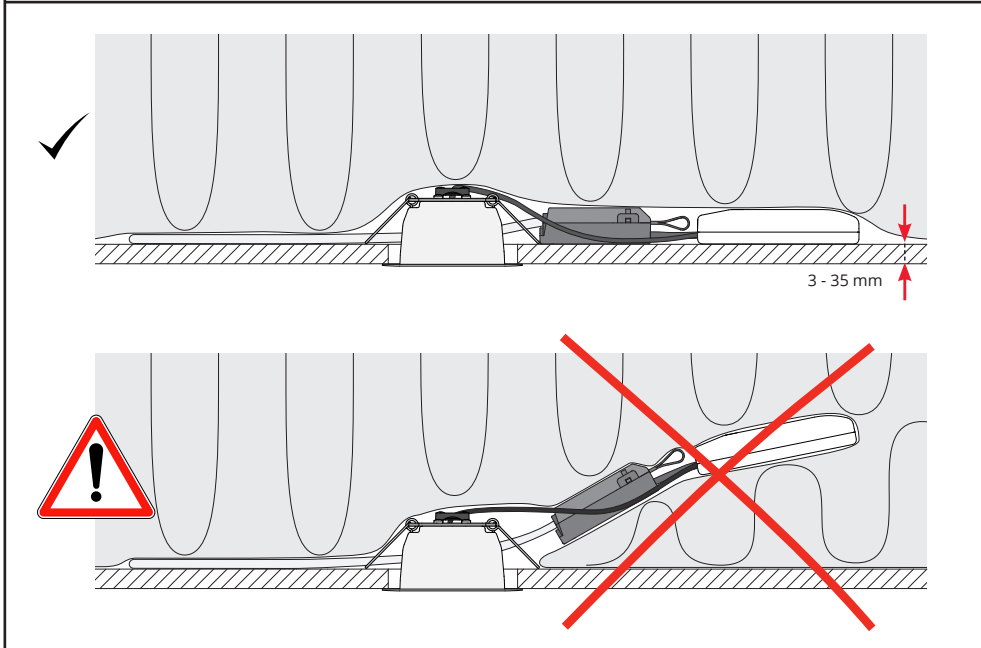
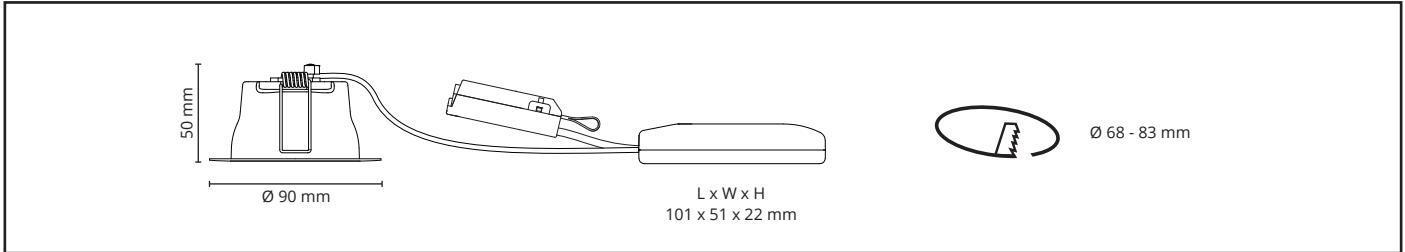

NO: Kan kun installeres av en registrert installasjonsvirksomhet.
EN: Only to be installed by an authorized electrician.
FR: Doit être installé par un électricien autorisé.
NL: Mag alleen geïnstalleerd worden door een bevoegde elektricien.
DE: Dieses Produkt darf nur durch autorisiertes Personal (z. B. Elektro-Installateur) angeschlossen und in Betrieb genommen werden.
FI: Asentaa saa vain valtuutettu sähköasentaja



NO: Skru av strømmen før montering.
EN: Turn off power before installing.
FR: Couper le courant avant l'installation.
NL: Stroom uitschakelen voor u het toestel installeert.
DE: Vor Installationsarbeiten den Strom abschalten.
FI: Sammuta virta ennen kytkemistä

NORWAY SG Armaturen AS
 Tlf:+47 37 50 03 00
 firmapost@sg-as.no
 www.sg-as.no

SWEDEN SG Armaturen AB
 Tel: +46 31 81 71 10
 info@sg-ab.se
 www.sg-ab.se

FRANCE SG Lighting SA/NV
 Tel: +33(0) 4 94 93 00 00
 info.france@sglighting.fr
 www.sglighting.net

GERMANY SG Leuchten GmbH
 Tel: +49 40 23 99 44 59
 info@sg-leuchten.de
 www.sg-leuchten.de

DENMARK SG Armaturen A/S
 Tel: +45 70 70 72 13
 info@sg-as.dk
 www.sg-as.dk

FINLAND SG Armaturen Oy
 info@sg-oy.fi
 www.sg-oy.fi

BENELUX SG Lighting SA/NV
 Tel: +32(0) 15 20 72 71
 info.benelux@sglighting.net
 www.sglighting.net

INTERNATIONAL SG Lighting Co Ltd.
 Tel: +86 769 88 49 20 88
 cindy@sgdgc.com
 www.sg-as.com