

BExBG15D-P-SIL / BExBG10D-P-SIL

The BExBG10D and BExBG15D beacons have been certified for use in locations with the following conditions:

**Area Classification Gas:**

Zone 1	Explosive gas atmosphere likely to occur in normal operation.
Zone 2	Explosive gas atmosphere not likely to occur in normal operation but may be present for short periods.

**Gas Groupings:**

Group IIA	Propane
Group IIB	Ethylene
Group IIC	Hydrogen and Acetylene

**Temperature Classification:**

T1	400° C
T2	300° C
T3	200° C
T4	135° C (up to +50° C ambient)

**Area Classification Dust:**

Zone 21	Explosive dust atmosphere likely to occur in normal operation.
Zone 22	Explosive dust atmosphere not likely to occur in normal operation but may be present for short periods.

**Dust Groups:**

Group IIIA	Combustible Dust
Group IIIB	Non-Conductive Dust
Group IIIC	Conductive Dust

**Maximum Surface Temperature for Dust Applications:**

120° C at +40° C ambient  
135° C at +55° C ambient  
150° C at +70° C ambient

**IP Rating:** IP66/67 to EN/IEC60529 and IP6X to EN/IEC60079-0, EN/IEC60079-31

**Equipment Category:** 2G / 2D

**Equipment Protection Level:** Gb / Db

**Ambient Temperature Range:**

-50° C to +70° C Gas Groups IIA, IIB and IIC  
-50° C to +70° C Dust Groups IIIA, IIIB and IIIC

SIL 2 Unit operating temperature range limits -25° C to +60° C

**1) Warnings**



- DO NOT OPEN WHEN AN EXPLOSIVE ATMOSPHERE IS PRESENT
- DO NOT OPEN WHEN ENERGIZED
- POTENTIAL ELECTROSTATIC CHARGING HAZARD
- COVER BOLTS CLASS A4-80
- USE HEAT RESISTING CABLES AND CABLE GLANDS (RATED 110° C) AT AMB. TEMPERATURES OVER 40° C

**2) Rating & Marking Information**

All units have a rating label, which carries the following important information:-

**Model No.:** BExBG15D-P-SIL or BExBG10D-P-SIL

**Input Voltage:** DC Units 24V

**BExBG10D-P-SIL & BExBG15D-P-SIL Codes:**

- Ex d IIC T4 Gb Ta. -50° C to +50° C
- Ex d IIC T3 Gb Ta. -50° C to +70° C
- Ex tb IIIC T120° C Db Ta. -50° C to +40° C
- Ex tb IIIC T135° C Db Ta. -50° C to +55° C
- Ex tb IIIC T150° C Db Ta. -50° C to +70° C

**Certificate No.** KEMA 00ATEX2006X  
IECEX KEM 10.0002X

Epsilon x:  
Equipment Group and  
Category:

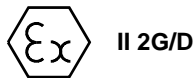

**CE Marking**  
Notified Body No.



### 3) Type Approval Standards

The beacons have an EC Type examination certificate and IECex Certificate of Conformity issued by Dekra and have been approved to the following standards:

EN60079-0:2012+A11:2013 / IEC60079-0:2011 (Ed6):  
Explosive Atmospheres - Equipment. General requirements

EN60079-1:2007 / IEC60079-1:2007 (Ed6):  
Explosive Atmospheres - Equipment protection by flameproof enclosures "d"

EN60079-31:2014 / IEC60079-31:2013 (Ed2):  
Explosive Atmospheres - Equipment dust ignition protection by enclosure "t"

### 4) Installation Requirements

The beacons must only be installed by suitably qualified personnel in accordance with the latest issues of the relevant standards:

EN60079-14 / IEC60079-14: Explosive atmospheres - Electrical installations design, selection and erection

EN60079-10-1 / IEC60079-10-1: Explosive atmospheres - Classification of areas. Explosive gas atmospheres

EN60079-10-2 / IEC60079-10-2: Explosive atmospheres - Classification of areas. Explosive dust atmospheres

The installation of the units must also be in accordance with any local codes that may apply and should only be carried out by a competent electrical engineer who has the necessary training.

### 5) Special Conditions of Use

Repair of the flamepath / flameproof joints is not permitted.

The enclosure is non-conducting and may generate an ignition-capable level of electrostatic charges under certain extreme conditions (such as high-pressure steam). The user should ensure that the equipment is not installed in a location where it may be subjected to external conditions that might cause a build-up of electrostatic charges on non-conducting surfaces.

Additionally, cleaning of the equipment should be done only with a damp cloth.

### 6) Beacon Location and Mounting

The location of the beacons should be made with due regard to the area over which the warning signal must be visible. They should only be fixed to services that can carry the weight of the unit.

**SAFETY WARNING:** The BExBG10D-P and BExBG15D-P 15 and 10 joule beacons must be mounted with their flashdome in a position between upright and 90° as shown.

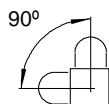

The BEx beacon should be securely bolted to a suitable surface using the 7mm diameter boltholes in the stainless steel U shaped mounting bracket (see figure 1). The angle can then be adjusted as required but the mounting restrictions must be observed (see above). This can be achieved by loosening the two large bracket screws in the side of the unit, which allow adjustment in steps of 18°. On completion of the installation the two large bracket adjustment screws on the side of the unit must be fully tightened to ensure that the unit cannot move in service.

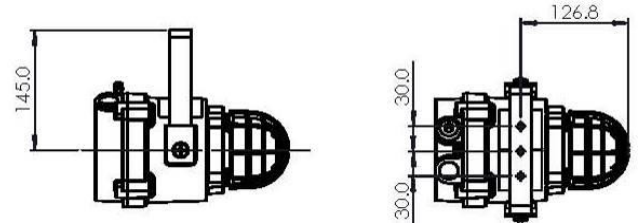

Fig 1. Fixing Location for Beacon

### 7) Access to the Flameproof Enclosure



Warning – High voltage may be present, risk of electric shock. DO NOT open when energised, disconnect power before opening.



Warning – Hot surfaces. External surfaces and internal components may be hot after operation, take care when handling the equipment.

To access the Ex d chamber, remove the four M6 hexagon socket head screws and withdraw the flameproof cover taking extreme care not to damage the flameproof joints in the process. M6 cover screws are Class A4-80 stainless steel and only screws of this category can be used for the enclosure.

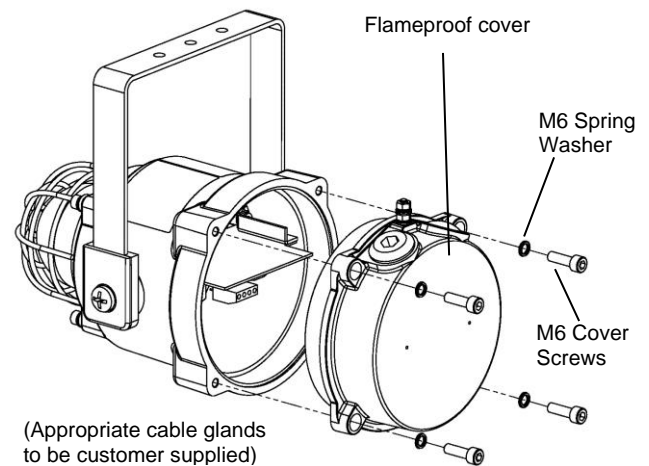

Fig. 2 Accessing the Explosion proof Enclosure.

On completion of the cable wiring installation the flameproof joints should be inspected to ensure that they are clean and that they have not been damaged during installation.

Check that the earth bonding wire between the two casting sections is secure and the 'O' ring seal is in place. When replacing the flameproof cover casting ensure that it is square with the flameproof chamber casting before inserting. Carefully push the cover in place allowing time for the air to be expelled. Only after the cover is fully in place should the four M6 Stainless Steel A4-80 cover bolts and their spring

washer be inserted and tightened down. If the cover jams while it is being inserted, carefully remove it and try again. Never use the cover bolts to force the cover into position.

## 8) Power Supply Selection

It is important that a suitable power supply is used to run the equipment. The power supply selected must have the necessary capacity to provide the input current to all of the units.

The following table shows the input current taken by the various beacons and shows the maximum voltage at which the beacons can be operated:

Model No.	Nominal I/P Voltage	Input Current	Voltage Range
BExBG10D-P-SIL	24Vdc	685mA	20-28V
BExBG15D-P-SIL	24Vdc	885mA	20-28V

The input current will vary according to the voltage input level. The current levels shown above are for nominal input voltage.

## 9) Selection of Cable, Cable Glands and Blanking elements

When selecting the cable size, consideration must be given to the input current that each unit draws (see table above), the number of beacons on the line and the length of the cable runs. The cable size selected must have the necessary capacity to provide the input current to all of the beacons connected to the line.

For ambient temperatures over +40°C the cable entry temperature may exceed +70°C and therefore suitable heat resisting cables and cable glands must be used, with a rated service temperature of at least 110°C

The BExBG10D and BExBG15D beacons have dual cable gland entries which have an M20 x1.5. The dual cable gland entries have an M20 x 1.5 entry thread. To maintain the ingress protection rating and mode of protection, the cable entries must be fitted with suitably rated ATEX / IECEx certified cable glands and/or suitably rated ATEX / IECEx certified blanking devices during installation according to EN / IEC60079-14.

If a high IP (Ingress Protection) rating is required then a suitable sealing washer must be fitted under the cable glands or blanking plugs.

For use in explosive dust atmospheres, a minimum ingress protection rating of IP6X must be maintained.

The BEx beacon range can be supplied with the following types of adapters:

- M20 to ½" NPT
- M20 to ¾" NPT
- M20 to M25

It is important to note that stopping plugs cannot be fitted onto adapters, only directly onto the M20 entries.

Any other adapters used must be suitably rated and ATEX / IECEx certified adapters.

## 10) Earthing

Both AC and DC beacon units must be connected to an earth. The units are provided with internal and external earthing terminals which are both located on the terminal chamber section of the unit.

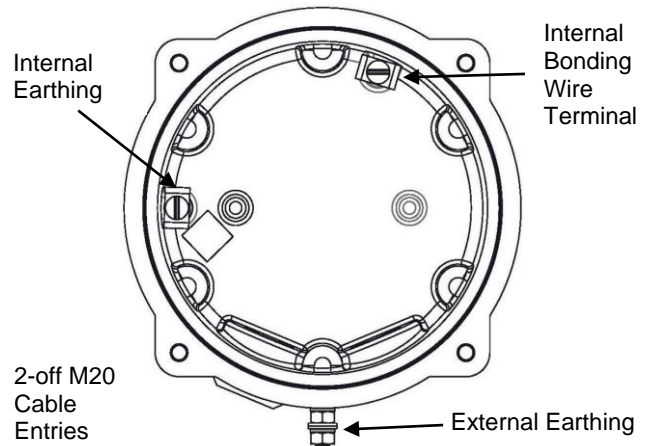

Fig 3. Internal View of Cover

When using the internal earth terminal ensure that the stainless steel M4 flat washer is between the incoming earth wire and the enclosure.

Internal earthing connections should be made to the Internal Earth terminal in the base of the housing using a ring crimp terminal to secure the earth conductor under the earth clamp. The earth conductor should be at least equal in size and rating to the incoming power conductors.

External earthing connections should be made to the M5 earth stud, using a ring crimp terminal to secure the earth conductor to the earth stud. The external earth conductor should be at least 4mm<sup>2</sup> in size.

## 11) Cable Connections

Electrical connections are to be made into the terminal blocks on the PCBA located in the flameproof enclosure. See section 7 of this manual for access to the flameproof enclosure. A four-way terminal block is provided on the beacons. Therefore, there are two +ve terminals and two -ve terminals for the input and output wiring.

Wires having a cross sectional area between 0.5 mm<sup>2</sup> to 2.5mm<sup>2</sup> can be connected to each terminal way. If an input and output wire is required the 2-off Live/Neutral or +/- terminals can be used. If fitting 2-off wires to one terminal way the sum of the 2-off wires must be a maximum cross sectional area of 2.5mm<sup>2</sup>. Strip wires to 8mm. Wires may also be fitted using ferrules. Terminal screws need to be tightened down with a tightening torque of 0.45 Nm / 5 Lb-in. When connecting wires to the terminals great care should be taken to dress the wires so that when the cover is inserted into the chamber the wires do not exert excess pressure on the terminal blocks. This is particularly important when using cables with large cross sectional areas such as 2.5mm<sup>2</sup>.

## 12) SIL 2 Instruction/Safety Manual

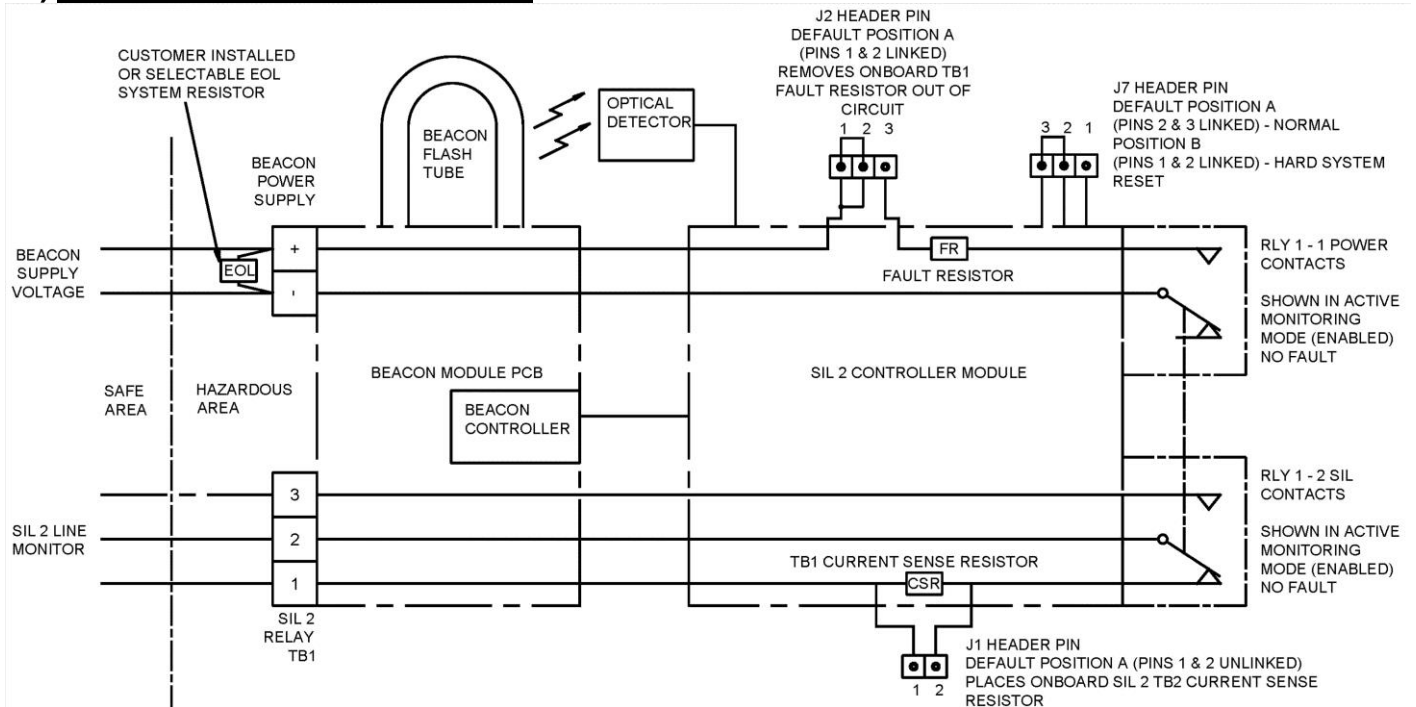

Fig 4 - The SIL 2 Module monitors the Beacon and interfaces to the customer plant.

**Warning** – To maintain the integrity of the SIL 2 units the system must be installed in accordance with this manual. Any deviation could result in failure of the SIL 2 system and an unintended unit operation or function.

**Warning** – Unit must be installed, commissioned and used within the parameters outlined in this manual. Failure to comply with this will result in potential unit failure within the system.

**Warning** – The unit must be powered in either Standby or Active modes to comply with the SIL 2 approval requirement.

**Warning** – If the power is disrupted the unit must be allowed to go through the commissioning cycle to reset, if this does not happen and the power continues to be disrupted the unit will latch the fault and require a hard system reset.

### SIL 2 System Description

The E2S BEx range of IECEx & ATEX compliant signaling devices with integrated SIL 2 fault monitoring modules.

The SIL 2 module monitors the function of the device and provides feedback to the control panel. A fault condition can be communicated via independent fault contacts or by the introduction to the monitoring circuit of an end of line resistor. A SIL 2 system wiring for fault detection in standby and active mode – 4 wire installation can be seen as per section 14.1. A SIL 2 system wiring for fault detection in standby and active mode – 2 wire installation can be seen as per section 14.2.

The new SIL 2 version of the E2S BExS110-SIL & BExS120-SIL alarm horn sounder and BExBG05-SIL, BExBG10-SIL & BExBG15-SIL Xenon strobe beacon are designed, tested and certified, bringing plant safety to new levels.

#### Key benefits:

- Signaling device function is checked and automatically reported to the control panel.
- Eliminates the need for time consuming physical inspections.
- Increased plant safety, confidence that all devices are fully functioning.
- Designed to integrate seamlessly into your SIL 2 environment.

## 13) SIL 2 System Terms and Function

The SIL 2 Beacon Unit Monitors

- Standby mode and Active mode
- Health status of power supply
- Beacons correct function and flash pattern

The SIL 2 beacon operates as part of a SIL 2 system.

The beacon will after commissioning remain powered in **Standby mode** (reverse polarity) until the beacon is required to operate. When the signaling device is required to operate beacon the polarity is changed back to normal supply and the beacon will go into **Active mode** where it will start to function/flash. When testing the system and beacons operation, the system is put into **Active mode**.

The customer PLC will control whether the system is in either of the main two operational modes.

**Standby Mode** – This is where the power supply polarity is reversed so negative (–ve) is feed to the positive (+) beacon terminal and positive (+) is feed to the negative (–ve) beacon terminal.

In this mode the beacon will not flash but the SIL 2 unit is monitoring power supply and is set-up ready to go to Active (alarm) mode.

Power relay RLY1-1 will be open whilst SIL 2 relay RLY1-2 will be closed contact between terminals 1 & 2.

If power is disrupted the SIL 2 unit will go into **Fault mode**, in fault mode the Power relay RLY1-1 will close whilst SIL 2 relay RLY1-2 will become open circuit between terminals 1 & 2.

**Active Mode** – This is where the power is in normal polarity, positive (+) supplied to the positive (+) beacon terminal and negative (–ve) is supplied to the negative (–ve) beacon terminal.

In this mode the beacon will flash giving the warning signal, the SIL 2 unit is actively checking the beacons function for flash output and beacon controller signal generation to the right flash frequency.

Power relay RLY1-1 will be open whilst SIL 2 relay RLY1-2 will be closed contact between terminals 1 & 2.

The SIL 2 unit will also check for signal polarity.

If a fault is found the SIL 2 unit will go into **Fault mode**.

If power is disrupted the SIL 2 unit will go into **Fault mode**, in fault mode the Power relay RLY1-1 will close whilst SIL 2 relay RLY1-2 will become open be circuit between terminals 1 & 2.

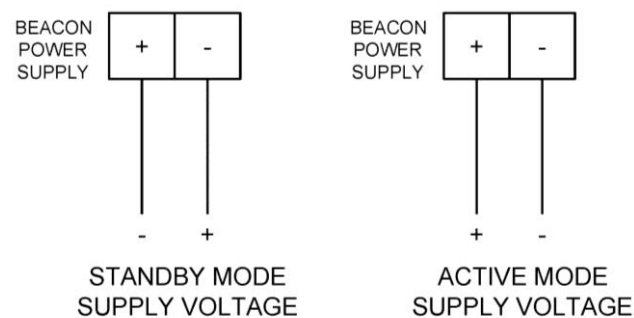

**Fault modes** - The fault modes listed 13-1 & 13-2 below will make the SIL 2 unit change the state of the fault relays  
In fault mode the Power relay RLY1-1 will close whilst SIL 2 relay RLY1-2 will become open be circuit between terminals 1 & 2.

### 13-1 Beacon Failure

- Flash Failure – No Flash detected
- Beacon Controller failure – No flash trigger pulse detected
- Flash Rate Failure – Regular 1 Hz flash cycle erratic

Resetting Failure - It is possible that the SIL 2 unit can be reset by powering the unit off for a period greater than 20 seconds. On restarting the unit and running through the commissioning cycle, the fault may clear. It is necessary to run the test function cycle again to see if the fault is still evident. If the relays activate again the unit must be checked as it is showing a failure and may not be functioning correctly.

### 13-2 Power Failure / SIL 2 Failure

- SIL 2 Controller failure – Internal function and system checking flags fault
- Rapid Power cycling – System indicates power instability
- Total Power Failure

Resetting Failure - It is possible that the SIL 2 unit can be reset by hard resetting the unit using the reset jumper within the unit (see section 21) on hard resetting.

On restarting the unit and running through the commissioning cycle, the fault may clear. It is necessary to run the test function cycle again to see if the fault is still evident. If the relays activate again the unit must be checked as it is currently showing a failure and may not be functioning correctly.

### Commissioning System - Functional start-up of System (Normally in reverse polarity mode)

When Commissioning system the power must not be disrupted to the SIL 2 Unit within the unit's initialization cycle which is **5 seconds**.

Once past this period the SIL 2 system is fully operational and will be in monitoring the beacon and power in Standby mode.

The relay RLY1-2 on the SIL 2 unit will only remain open for a maximum of 1 second on commissioning start-up.

Then they will close contact 1 & 2 showing healthy operation and only open in the event of a fault or power down.

### System Testing (Active Mode normal polarity)

The SIL 2 system will remain monitoring the power in standby mode until the polarity is changed to normal mode to enable an active system for beacon functional testing.

**Important:** - The polarity must be held in active mode for a period in excess of **15 seconds** to ensure a full system check is performed.

Whilst the system is being checked the beacon controller and flash pulses are monitored and checked for correct pattern timing.

Once the test period has been completed the unit can be switched back to standby mode by reversing the polarity.

If no faults have been found during the test the relays will remain in there steady state.

The SIL 2 unit will continue to monitor the power and mode.

**Important:** - The automated test cycle **must** be undertaken on at least a weekly basis to maintain the SIL 2 units reliability.

### System Activation (Active Mode normal polarity)

The SIL 2 system will remain monitoring the power in standby mode until the polarity is changed to Active mode to enable an active system for beacon to function as a warning signaling device.

**Important:** :- The polarity must be held in active mode for a period in excess of 15 seconds to ensure a full system check is performed whilst in alarm mode, although it is expected that during a system activation this period will be significantly greater.

**Note** :- The fault indication signal on TB1 can take up to 1.5 seconds to indicate system fault.

## 14) SIL 2 Wiring configuration and Beacon set-up

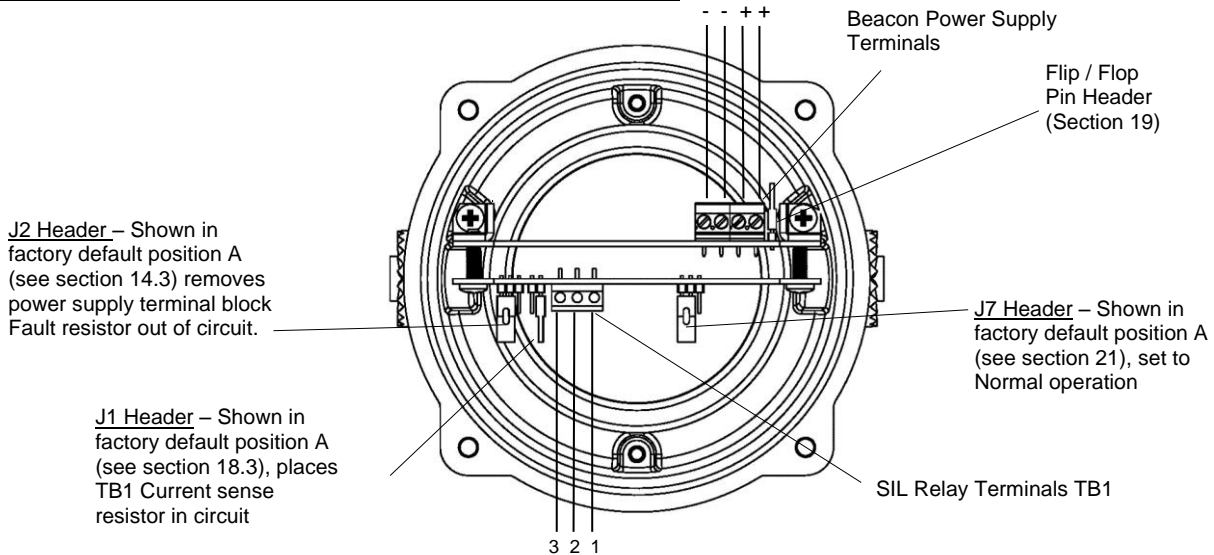

Figure 5 – Terminals and header pins for beacon

Power & Communication with the system control panel can be configured in two ways: - Although it is **highly** recommended that the unit is wired as stated in this section 14-1

- **14-1 SIL 2 system wiring for fault detection in standby and active mode – 4 wire installation (Recommended)**

The customer is required to wire into both the beacon power supply terminals and also the SIL 2 Relay terminals TB1

The power supply terminals only need to have the supply power connected. This will be reverse polarity for monitoring mode and normal polarity for active mode. There is no need to fit an EOL resistor on the power supply terminal as the TB1 is configured to raise a fault alarm in any situation.

TB1 the SIL 2 monitoring relay, RLY 1-2 on the SIL 2 board which whilst powered is closed between TB1 terminals 1 & 2, however on any fault will become an open circuit between TB1 terminals 1 & 2. The fault will be seen via the SIL 2 TB1 terminals as soon as the fault occurs in either Active or Standby modes.

As factory default when there is no fault, the TB1 terminals 1 & 2 will be closed putting a 3.3kΩ current sense resistor in line. If the circuit is driven with 24V dc the detection current seen is ~7.3mA @ 24V. System faults will make RLY 1-2 contacts go open circuit between terminals 1 & 2 for any fault mode. The only other fault mode is if the cable goes short circuit where a short will be seen by the panel.

There is an option (although not recommended) to alter the enable J1 header pin to link pins 1 & 2 (see figure 8) which shorts out the 3.3KΩ current sense resistor making TB1 terminal 1 & 2 into a switch. The disadvantage is that a short circuit on this cable will not be detected

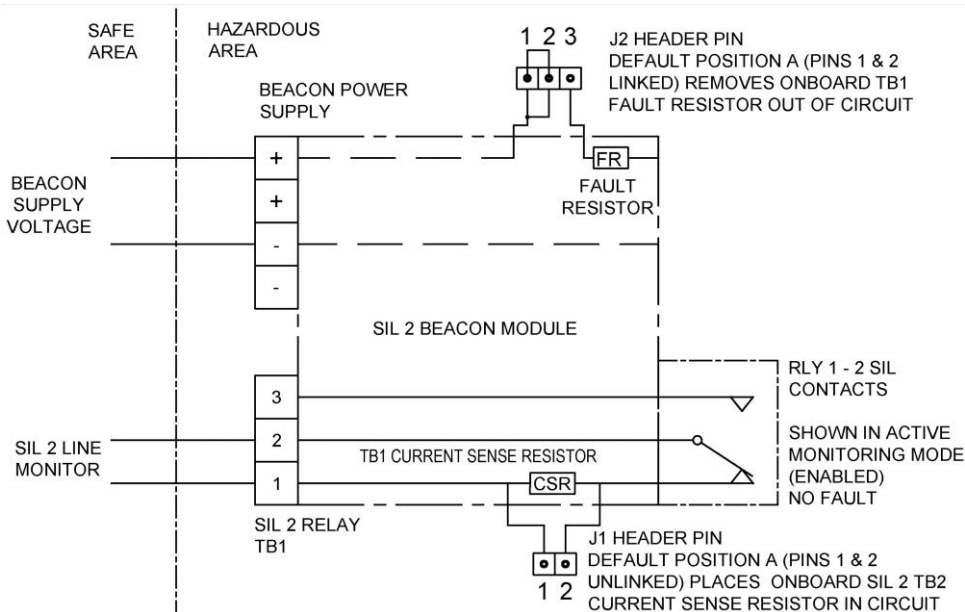

For one unit only:

Beacon power supply terminal block	Current drawn (mA)
Active Mode	190mA
Standby Mode	25mA

TB1 Current Sense Resistor value	Current drawn (mA)
3.3kΩ	7.2mA

On fault mode, current drops to 0 as circuit goes open.

Figure 6 – Schematic of SIL 2 system wiring for fault detection in standby and active mode – 4 wire installation

## Multiple Unit Configuration

When multiple units are used in the system, the following considerations are to be made by the customer:

1. Customer panel capabilities -  
The customer is required to identify the minimum change in current the panel can detect (Panel resolution). This will therefore determine what resistors values to pick in section 3 below.
2. Topology -  
The customer has a number of options on how to set up the system.
  - A single unit topology is where only one unit is connected to the customer interface line, as shown in figure 6.
  - A series topology is where each unit is connected to one another as shown in figure 14.
  - A star topology is where each unit is connected to a central source as shown in figure 15.
3. Resistor – TB1 Current Sense Resistor (default 3.3kΩ)  
The customer is required to calculate the total resistance of the system, to determine the change in current when a fault occurs. The default customer sense resistor value is 3.3kΩ. Examples of calculations of resistance for steady mode and fault mode are shown in table 1.

Panel Resolution	Topology	Resistor: TB1 CSR	No. of Units	Steady Mode: Active/Monitoring	Fault Mode	
					1 unit fault	All units fault
2mA	Series	3.3kΩ	3	$3 \times 3.3k\Omega = 9.9k\Omega$ $\frac{24}{9.9k\Omega} = 2.4mA$	0mA If one unit fails the whole system fails	
7mA	Star	3.3kΩ	3	$(3.3k\Omega \sim 7.3mA)$ $3 \times 7.3mA = 21.9mA$	(Fault unit): $1 \times 0mA = 0mA$ (Normal): $2 \times 7.3mA = 14.6mA$	(Fault unit): $3 \times 0mA = 0mA$
1.5mA	Series	3.3kΩ	4	$4 \times 3.3k\Omega = 13.2k\Omega$ $\frac{24}{13.2k\Omega} = 1.8mA$	0mA If one unit fails the whole system fails	
7mA	Star	3.3kΩ	4	$(3.3k\Omega \sim 7.3mA)$ $4 \times 7.3mA = 29.2mA$	(Fault unit): $1 \times 0mA = 0mA$ (Normal): $3 \times 7.3mA = 21.9mA$	(Fault unit): $4 \times 0mA = 0mA$

Table 1

Note: - Cable fault

- Between the panel and the first unit, a cable short, increases the current (presenting a short circuit to the panel), and a cable cut/open reduces current (presenting an open circuit to the panel).
- In series topology a cable short between units will short out one of the current sense resistors which results in an increase in the current used by the unit, and a cable cut/open reduces current (presenting an open circuit to the panel).
- In star topology a cable short between units will short circuit the SIL 2 monitoring line hence presenting a short circuit to the panel, an open circuit fault on one of the units will effectively remove one of the current sense resistors reducing total effective resistance hence decreasing the total current seen by the panel.

• **14-2 SIL 2 system wiring for fault detection in standby mode only – 2 wire installation**

The customer is required to wire into power supply terminal only. The unit will be monitored in standby mode only, via an customer installed system EOL resistor (2.2kΩ suggested customer EOL and default 2.2kΩ fault resistor will draw a total current of 35.9mA @ 24Vdc as shown in table 2).

In the event of a fault, The SIL 2 unit will automatically place the power supply terminal fault resistor across the power terminals which already has customer EOL resistor (2.2kΩ) in place. This will result in a total fault detection current of 41.8mA @ 24V but can only be detected when unit is in Standby Mode.

If the customer chooses to use this configuration within their system, it must be noted that the factory default settings for the unit does not have an EOL resistor installed. The customer can request E2S to install an EOL resistor and this will be depicted in the product code. See section 25 for further information on EOL and fault resistor value choice.

**Important:** - This configuration will not warn of a fault whilst in Active mode as the PLC will be supplying the unit with power. The PLC will only be able to see the fault when in standby mode, by measuring the fault detection current.

**Important:** - This configuration requires the customer to set J2 header pin to be set to position B (see figure 9), as the units default position is A.

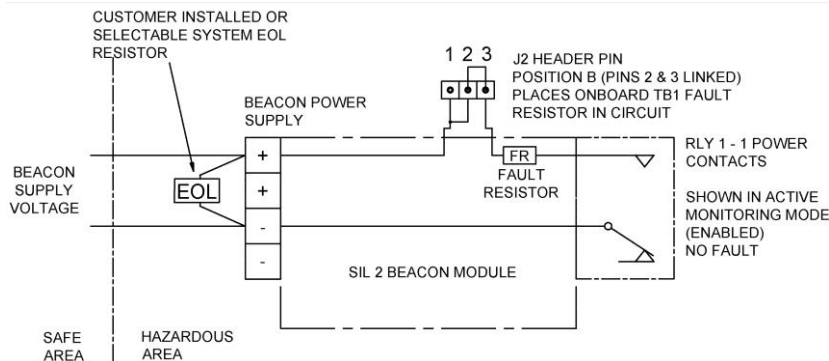

Figure 7 - Schematic of SIL 2 system wiring for fault detection in standby mode only – 2 wire installation

To evaluate the total current drawn from the SIL 2 unit, use the equation below.

$$I_{\text{(Total Current drawn)}} = I_{FR} \text{ (Current drawn from Fault Resistor)} + I_{EOL} \text{ (Current drawn from Customer EOL resistor)} + I_{SIL} \text{ (Current drawn from SIL board)}$$

In standby mode, where there is no fault, RLY 1-1 is open. This means the voltage only passes through the customer EOL resistor and the current drawn from the SIL 2 board is 25mA. Therefore, the equation for a No Fault scenario is then:

$$I_{NF} \text{ (Standby Mode, Total Current drawn - No Fault)} = I_{FR} \text{ (0mA)} + I_{EOL} \text{ (See table 2)} + I_{SIL} \text{ (25mA)}$$

In standby mode, where there is a fault, the circuit is closed. This means the voltage passes through both the customer EOL resistor and current sense resistor and the current drawn from the SIL 2 board is 20mA. The customer must first calculate the resistance of the two resistors in parallel before applying the currents to the equation. The equation for a Fault scenario is then:

$$I_F \text{ (Standby Mode, Total Current drawn - Fault)} = I_{TR} \text{ (Total Resistance when EOL & FR in parallel)} + I_{SIL} \text{ (20mA)}$$

Standby Mode	Power Supply Fault Resistor		Customer EOL Resistor		(Fault Mode Only)		Current drawn from SIL Board	Total current drawn
	Resistor Value	Current drawn ( $I_{FR}$ )	Resistor Value	Current drawn ( $I_{EOL}$ )	Total resistance	Current drawn ( $I_{TR}$ )		
No Fault	2.2 kΩ	0 mA	2.2 kΩ	10.9 mA	-	-	25 mA	35.9 mA
Fault		-		-	1.1 kΩ	21.8 mA	20 mA	41.8 mA
No Fault	1.0 kΩ	0 mA	1.0 kΩ	24.0 mA	-	-	25 mA	49.0 mA
Fault		-		-	500 Ω	48.0 mA	20 mA	68.0 mA
No Fault	2.2 kΩ	0 mA	3.3 kΩ	7.3 mA	-	-	25 mA	32.3 mA
Fault		-		-	1.3 kΩ	18.2 mA	20 mA	38.2 mA
No Fault	1.8 kΩ	0 mA	3.9 kΩ	6.2 mA	-	-	25 mA	31.2 mA
Fault		-		-	1.2 kΩ	19.5 mA	20 mA	39.5 mA
No Fault	1.8 kΩ	0 mA	4.7 kΩ	5.1 mA	-	-	25 mA	30.1 mA
Fault		-		-	1.3 kΩ	18.4 mA	20 mA	38.4 mA
No Fault	2.2 kΩ	0 mA	4.7 kΩ	5.1 mA	-	-	25 mA	30.1 mA
Fault		-		-	1.5 kΩ	16.0 mA	20 mA	36.0 mA

Table 2: Resistor combinations and the currents drawn when no faults and faults occur



## Multiple Unit Configuration

When multiple units are used in the system, the following considerations are to be made by the customer:

1. Customer panel capabilities -  
The customer is required to identify the minimum change in current the panel can detect (Panel resolution). This will therefore determine what resistors values to pick in section 3 below.
2. Topology -  
The customer has a number of options on how to set up the system.
  - A single unit topology is where only one unit is connected to the customer interface line, as shown in figure 7.
  - A series topology is when each unit is connected to one another as shown in figure 16.
  - A star topology is when each unit is connected to a central source as shown in figure 17.
3. Resistor -  
The customer is required to calculate the total resistance a system, to determine the change in current when a fault occurs. As mentioned above, the customer can select a system EOL resistor. The default fault resistor value is 2.2kΩ which is recommended and is fitted according to the configuration topology chosen.

Panel Resolution	Topology	Resistor: Power Supply FR & EOL	No. of Units	Steady Mode Active/ Monitoring	Fault Mode		
					1 unit fault	2 units fault	All units fault
5.5mA	Series	FR = 2.2kΩ & EOL = 2.2kΩ	3	EOL Only	EOL + FR	EOL + (2 x FR)	EOL + (3 x FR)
				$\frac{24}{2.2k\Omega} = 10.9mA$ $3 \times 25mA = 75mA$ $I = 85.9mA$	$R_T = 1.1k\Omega$ $\frac{24}{1.1k\Omega} = 21.8mA$ $2 \times 25mA = 50mA$ $1 \times 20mA = 20mA$ $I = 91.8mA$	$R_T = 0.7k\Omega$ $\frac{24}{0.7k\Omega} = 32.7mA$ $1 \times 25mA = 25mA$ $2 \times 20mA = 40mA$ $I = 97.7mA$	$R_T = 0.55k\Omega$ $\frac{24}{0.55k\Omega} = 43.6mA$ $3 \times 20mA = 60mA$ $I = 103.6mA$
5.5mA	Star	FR = 2.2kΩ & EOL = 2.2kΩ	3	3 x EOL	(3 x EOL) + (1 x FR)	(3 x EOL) + (2 x FR)	(3 x EOL) + (3 x FR)
				$R_T = 0.7k\Omega$ $\frac{24}{0.7k\Omega} = 32.7mA$ $3 \times 25mA = 75mA$ $I = 107.7mA$	$R_T = 0.55k\Omega$ $\frac{24}{0.55k\Omega} = 43.6mA$ $2 \times 25mA = 50mA$ $1 \times 20mA = 20mA$ $I = 113.6mA$	$R_T = 0.44k\Omega$ $\frac{24}{0.44k\Omega} = 54.5mA$ $1 \times 25mA = 25mA$ $2 \times 20mA = 40mA$ $I = 119.5mA$	$R_T = 0.36k\Omega$ $\frac{24}{0.36k\Omega} = 66.6mA$ $3 \times 20mA = 60mA$ $I = 126.6mA$
5.5mA	Series	FR = 2.2kΩ & EOL = 3.3kΩ	3	EOL Only	EOL + FR	EOL + (2 x FR)	EOL + (3 x FR)
				$\frac{24}{3.3k\Omega} = 7.3mA$ $3 \times 25mA = 75mA$ $I = 82.3mA$	$R_T = 1.3k\Omega$ $\frac{24}{1.3k\Omega} = 18.2mA$ $2 \times 25mA = 50mA$ $1 \times 20mA = 20mA$ $I = 88.2mA$	$R_T = 0.8k\Omega$ $\frac{24}{0.8k\Omega} = 30mA$ $1 \times 25mA = 25mA$ $2 \times 20mA = 40mA$ $I = 95mA$	$R_T = 0.6k\Omega$ $\frac{24}{0.6k\Omega} = 40mA$ $3 \times 20mA = 60mA$ $I = 100mA$
5.5mA	Star	FR = 2.2kΩ & EOL = 3.3kΩ	3	3 x EOL	(3 x EOL) + (1 x FR)	(3 x EOL) + (2 x FR)	(3 x EOL) + (3 x FR)
				$\frac{24}{1.1k\Omega} = 21.8mA$ $3 \times 25mA = 75mA$ $I = 96.8mA$	$R_T = 0.7k\Omega$ $\frac{24}{0.7k\Omega} = 32.7mA$ $2 \times 25mA = 50mA$ $1 \times 20mA = 20mA$ $I = 102.7mA$	$R_T = 0.55k\Omega$ $\frac{24}{0.55k\Omega} = 43.6mA$ $1 \times 25mA = 25mA$ $2 \times 20mA = 40mA$ $I = 108.6mA$	$R_T = 0.44k\Omega$ $\frac{24}{0.44k\Omega} = 54.5mA$ $3 \times 20mA = 60mA$ $I = 114.5mA$

Table 3

Note: - Cable fault

- Between the panel and the first unit, a cable short, increases the current (presenting a short circuit to the panel), and a cable cut/open reduces current (presenting an open circuit to the panel).
- In series topology a cable short between units will short out one of the current sense resistors which results in an increase in the current used by the unit, and a cable cut/open reduces current (presenting an open circuit to the panel).
- In star topology a cable short between units will short circuit the SIL 2 monitoring line hence presenting a short circuit to the panel, an open circuit fault on one of the units will effectively remove one of the current sense resistors reducing total effective resistance hence decreasing the total current seen by the panel.

- 14-3 Header Pins Settings

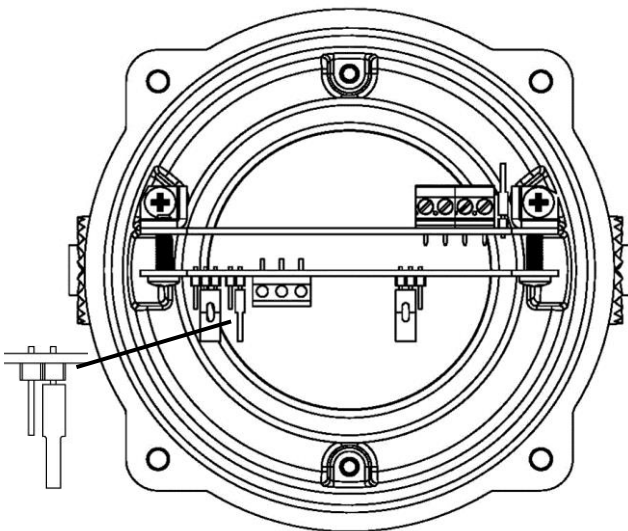

J1 Header Pin - Position A, Factory default position (pins 1 & 2 not linked) places TB1 Current sense resistor in circuit.

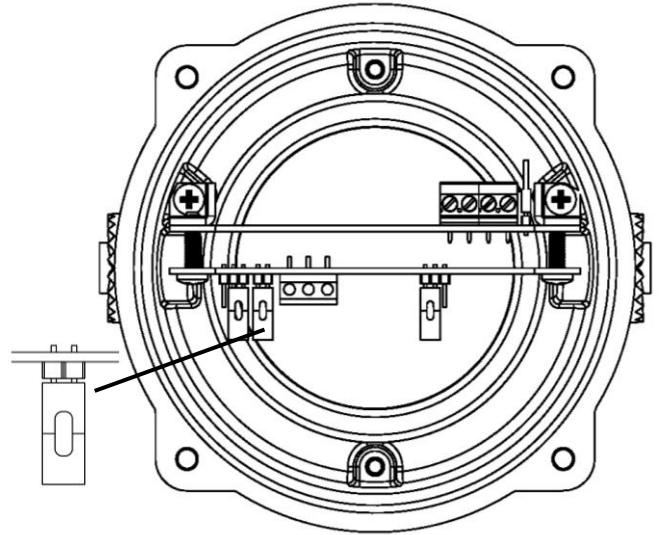

J1 Header Pin - Position B (pins 1 & 2 linked) removes TB1 Current sense resistor out of circuit.

Figure 8: J1 Header settings

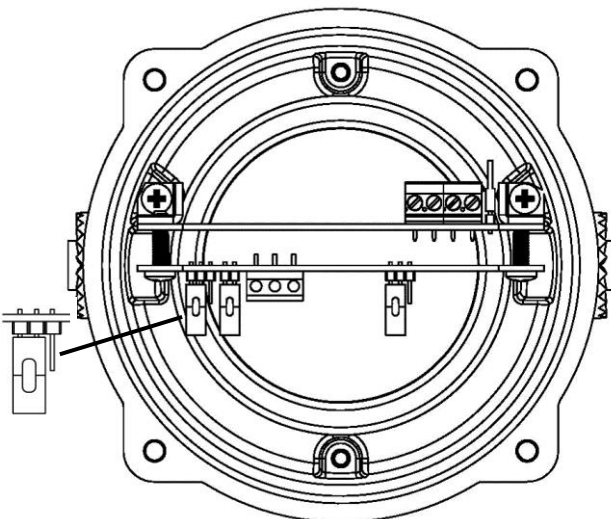

J2 Header Pin - Position A, Factory default position (pins 1 & 2 linked) removes power supply TB Fault resistor & RLY 1-2 out of circuit.

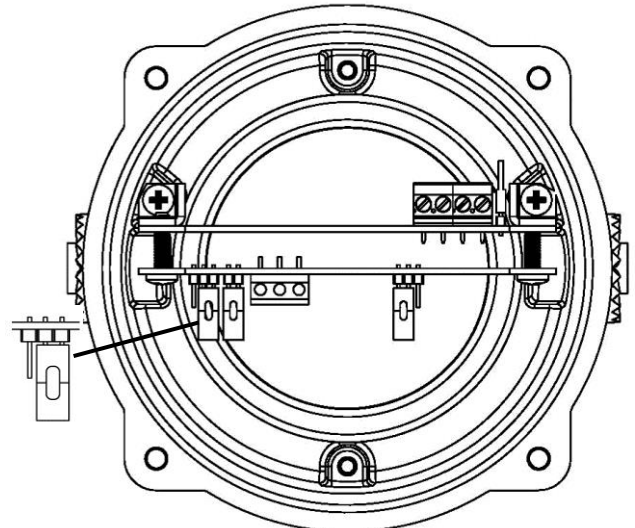

J2 Header Pin - Position B (pins 2 & 3 linked) places power supply TB Fault resistor & RLY 1-2 in

Figure 9: J2 Header settings

## 15) SIL Specific Unit Mounting Requirements

The beacon should be mounted no closer than 2m from a beacon or light source of similar candela output. This is to ensure false light activation does not occur when the unit is monitoring the light pulse duration and flash failure.

## 16) SIL 2 Reliability Data

Reliability and Functional safety IEC/EN61508 which has been assessed and is considered suitable for use in low demand safety function:

- Random Hardware Failures and Architectural constraints (route 1<sub>H</sub>)
- As an unvoted item (i.e. hardware fault tolerance of 0) at SIL 2

The product was assessed against failure modes:

- Failure respond to an input by lighting a beacon
- Spurious light output despite no input

Integrity in respect of failure to release	SIL 2
Total Failure rate	0.37 pmh
“hazardous” failure rate (revealed)	0.297 pmh
“hazardous” failure rate (unrevealed)	0.003 pmh
“safe” failure rate (revealed)	0.006 pmh
“safe” failure rate (unrevealed)	0
Diagnostic Coverage	99%
System type	B
Hardware Fault Tolerance	0
Safe Failure Fraction	>99%
PFD (hazardous failure)	$3.8 \times 10^{-5}$
Proof Test Interval	Up to 1 year

The SIL 2 units life is dependent on the cumulative running hour of the unit. The maximum running duration is 2,500 hours.

## 17) Synchronised Operation

All BExBG15D-SIL and BExBG10D-SIL beacons that are connected to the same supply line will have a synchronised flash rate at one flash every second. To ensure that the units will be synchronised check that the pin header is not fitted, i.e. the two header pins are not shorted together (see Figure 5).

## 18) Flip-Flop Operation

Two beacons can be mounted close to each other to form a flip-flop operation, where the beacons will flash alternately. To achieve this mode of operation, fit a pin header to the flip-flop header pins on the electronics board, i.e. the two header pins are shorted together, (see figure 5) on one of the two beacons. The first flash on the beacon that has the header fitted will be delayed by ½ second. The two beacons will then flash alternately every ½ a second.

## 19) End of Line Monitoring

On the BExBG15D-SIL and BExBG10D-SIL beacons, DC reverse line monitoring can be used if required. All DC beacons have a blocking diode fitted in their supply input lines. An end of line monitoring diode or an end of line monitoring resistor can be connected across the +ve and –ve terminals.

We suggest that with the SIL system the customer selected EOL resistor is kept to a value of 2.2kΩ however variation is allowed as required by the SIL systems PLC parameters. See section 14.2 and 22.

Values of current draw are given for the 2.2kΩ resistor if used as set up in section 14.

If an alternative value end of line resistor is used it must have a minimum resistance value of 3.3kΩ and a minimum wattage of 0.5 watts or a minimum resistance value of 500Ω and a minimum wattage of 2 watts.

## 20) SIL 2 Hard Reset

If required to hard system reset the unit, firstly, the unit will need to be opened, to carry out this operation see section 7.

**Warning:** - Ensure that an explosive atmosphere is not present during reset operation.

Power down the unit completely for a minimum of 30 seconds. Move the hard reset header pin (Jumper J7) to reset position shown. Then power the unit for a minimum of 5 seconds. Power down the unit for 30 seconds and then move the header pin back to the Normal Position.

The unit has been reset. Close the unit as noted in section 7. If the hard reset does not correct the fault the unit or power supply integrity will need further investigation.

## 21) Product Coding for Fault Resistor and Customer EOL Resistor

The customer is able to identify the resistor values chosen on purchase from the product code. This is represented by the last two characters:

BEXBG15D24DC-P-SIL-**XX**

The first character denotes the value of the Fault resistor and the second character denotes the value of the EOL resistor. The values of resistors available are shown in table 4.

Code	Resistor Value
A	2.2 k $\Omega$
B	1.0 k $\Omega$
C	1.5 k $\Omega$
D	1.8 k $\Omega$
E	2.7 k $\Omega$
F	3.3 k $\Omega$
G	3.9 k $\Omega$
H	4.7 k $\Omega$
J	5.6 k $\Omega$
K	6.8 k $\Omega$
L	8.2 k $\Omega$
M	11 k $\Omega$
Z	None Fitted

Table 4: Resistor values

For Example:

BEXBG15D24DC-AM-P-SIL-AZ

This shows a standard 5J 24V dc amber beacon with the suggested 2.2k $\Omega$  fault resistor and no customer installed or selectable EOL resistor.

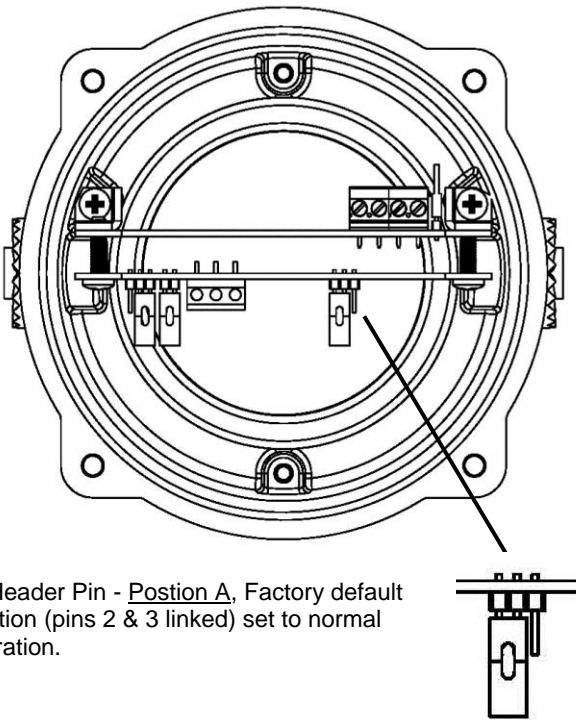

J7 Header Pin - Position A, Factory default position (pins 2 & 3 linked) set to normal operation.

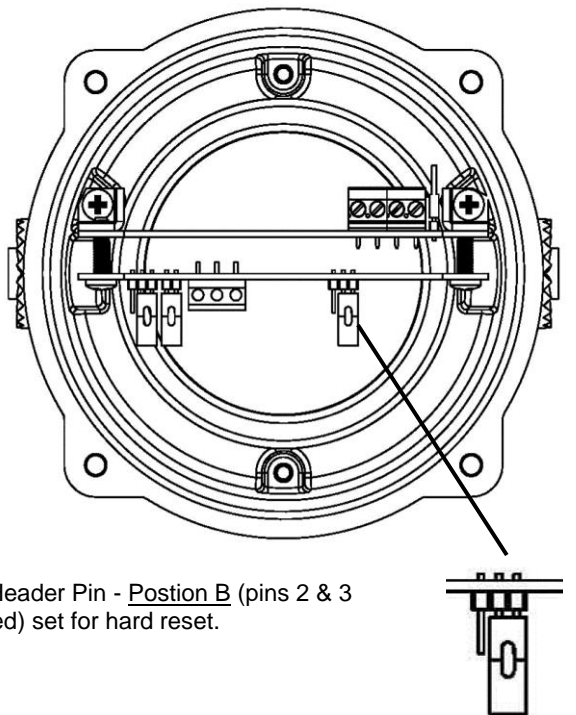

J7 Header Pin - Position B (pins 2 & 3 linked) set for hard reset.

Fig 10 – Jumper Settings

## 22) Interchangeable & Spare Parts



Warning – Hot surfaces. External surfaces and internal components may be hot after operation, take care when handling the equipment.

The beacon cover is interchangeable, contact E2S Ltd for a replacement cover available in various colours.

To change the cover, unscrew the M5 socket head screws and remove the M5 screws, M5 spring & flat washers.

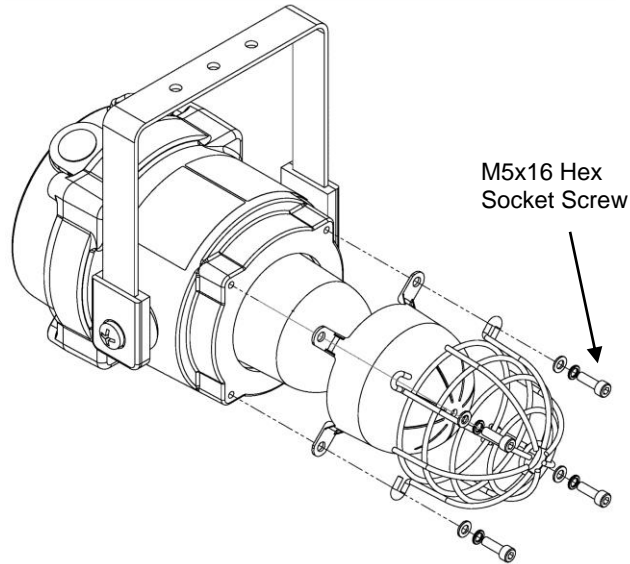

Fig. 11 Removal of cover

Remove the guard and replace the old cover with the new cover.

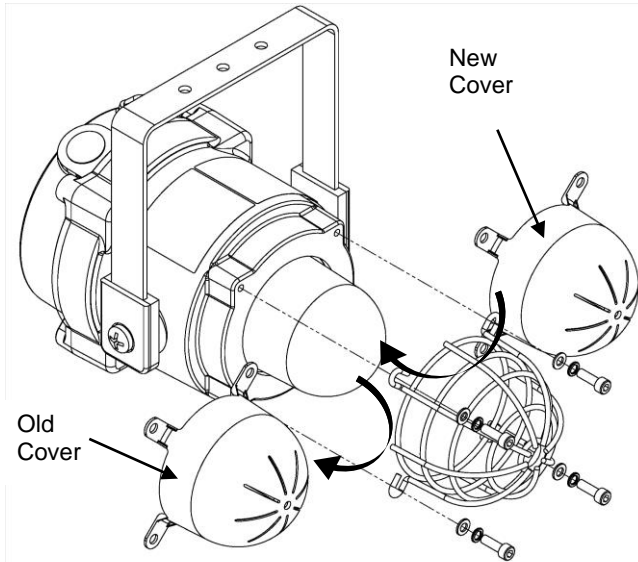

Fig. 12 Changing of cover

Fit the guard back on to the cover and casting, align the holes of the guard, cover and casting. To reattach the cover, the fixings **MUST** be in the order shown in figure 12.

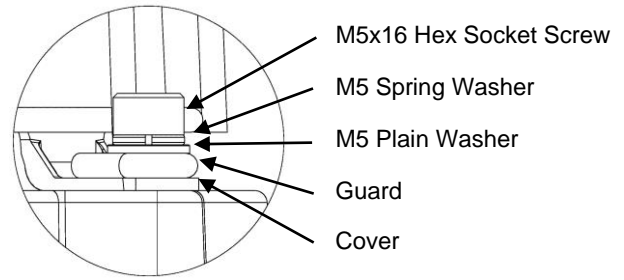

Fig. 13 Cover and Guard Fixtures

## 23) Maintenance, Overhaul and Repair

Maintenance, repair and overhaul of the equipment should only be carried out by suitably qualified personnel in accordance with the current relevant standards:

EN60079-19 Explosive atmospheres - Equipment repair, overhaul and reclamation  
IEC60079-19

EN 60079-17 Explosive atmospheres - Electrical installations inspection and maintenance  
IEC60079-17

To avoid a possible ELECTROSTATIC CHARGE the unit must only be cleaned with a damp cloth.

Units must not be opened while an explosive atmosphere is present.

If opening the unit during maintenance operations a clean environment must be maintained and any dust layer removed prior to opening the unit.

Flameproof threaded joints and cemented joints are not intended to be repaired.



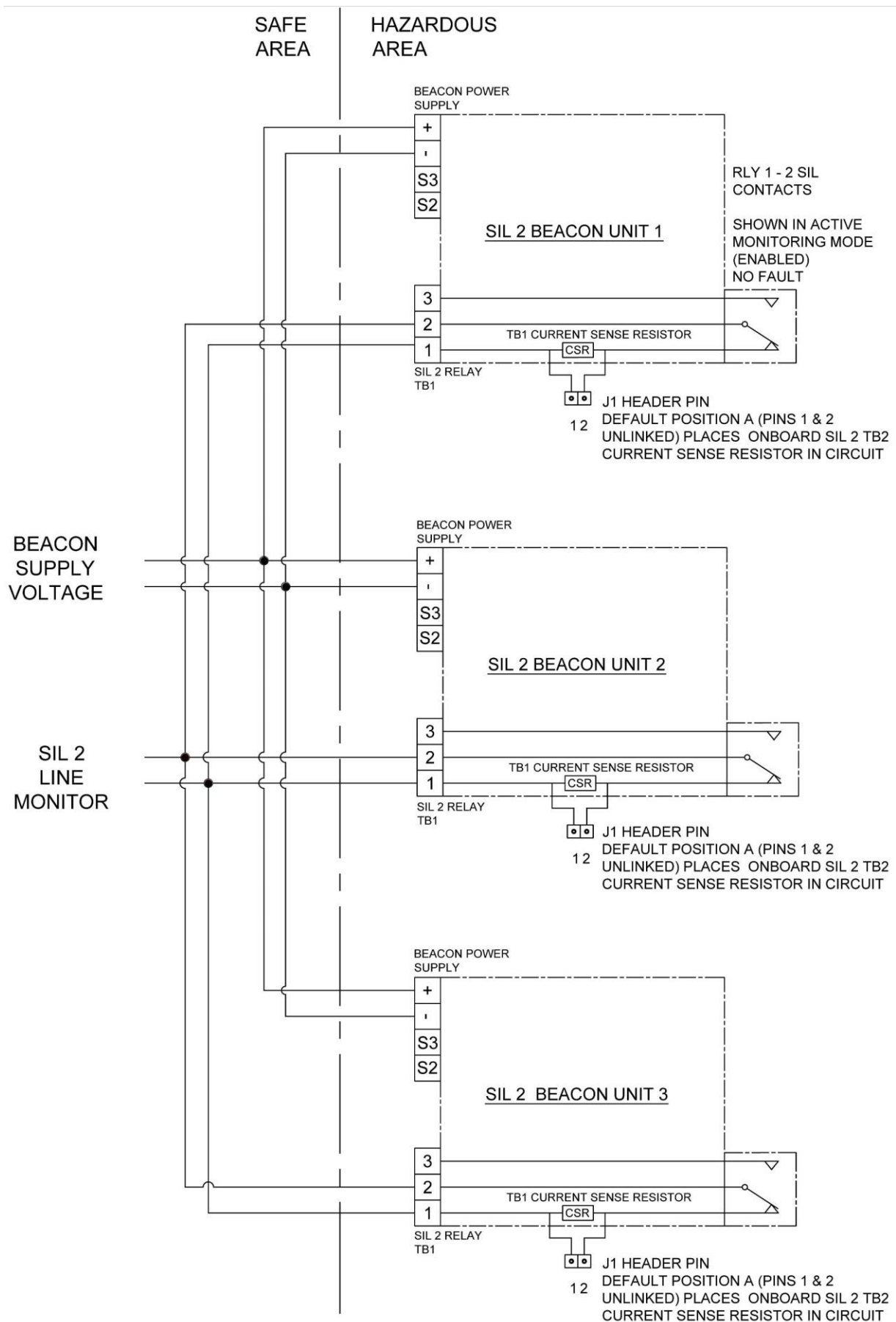

Figure 15: Schematic of SIL 2 system wiring for fault detection in standby mode only – 4 wire installation configuration in Star formation

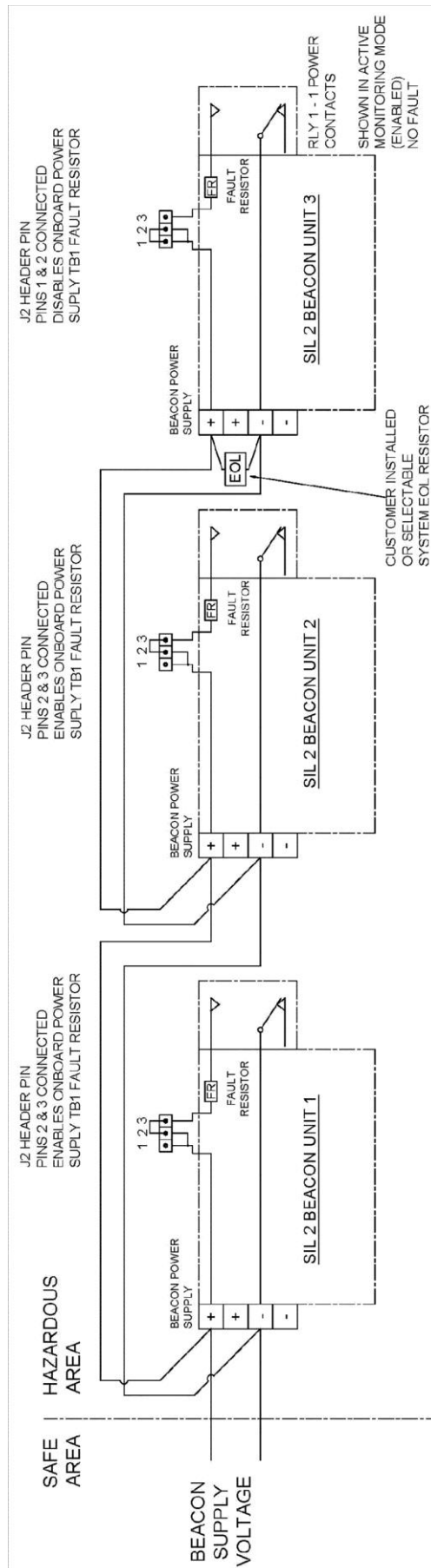

Figure 16: Schematic of SIL 2 system wiring for fault detection in standby mode only – 2 wire installation configuration wired in series



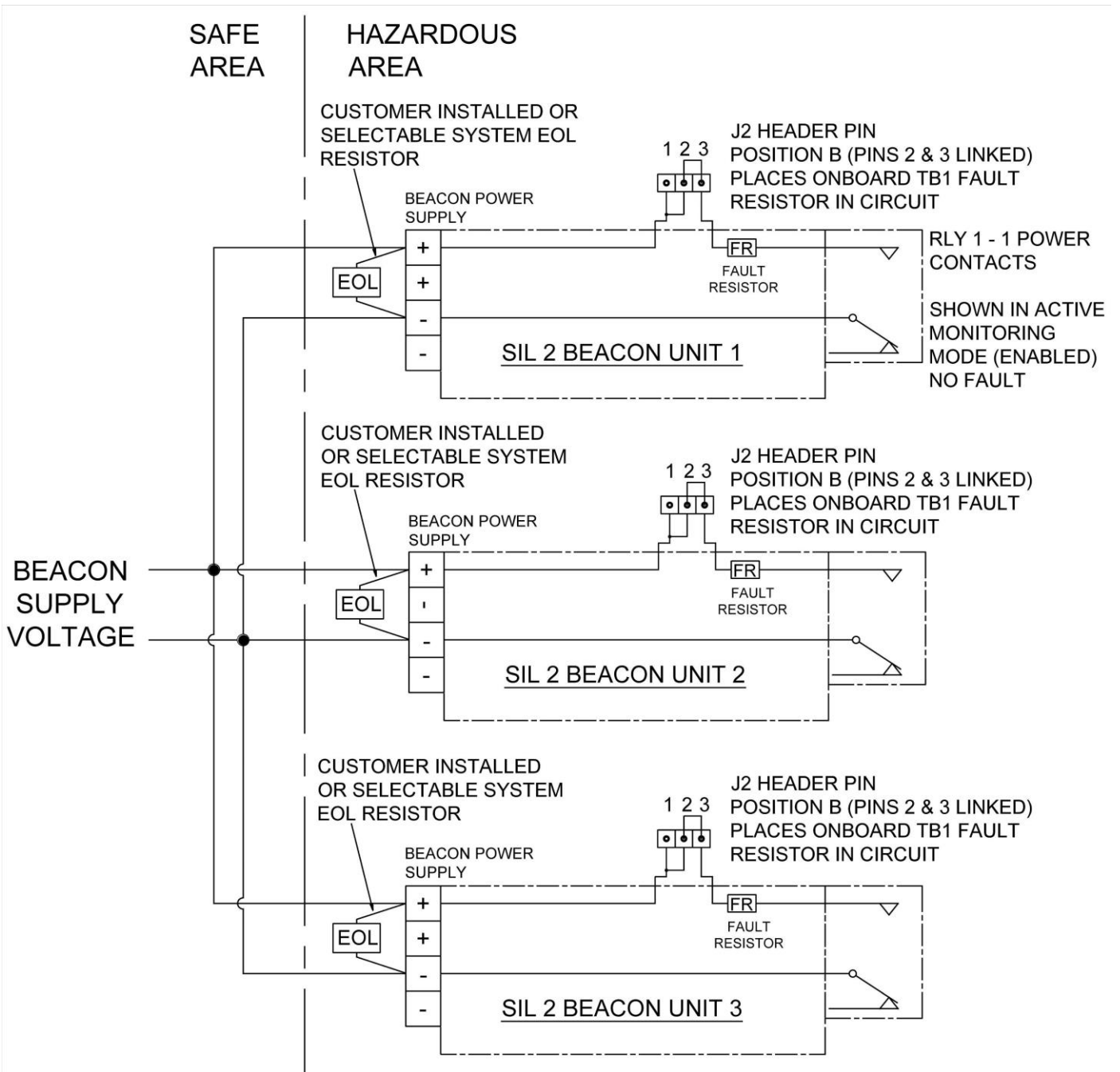

Figure 17: Schematic of SIL 2 system wiring for fault detection in standby mode only – 2 wire installation configuration in star formation

# EU Declaration of Conformity



Manufacturer: European Safety Systems Ltd.  
Impress House, Mansell Road, Acton  
London, W3 7QH, United Kingdom

Equipment Type: BExBG05D-SIL, BExBG10D-SIL, BExBG15D-SIL  
BExBG05D-P-SIL, BExBG10D-P-SIL, BExBG15D-P-SIL

---

## Directive 2014/34/EU: Equipment and Protective Systems for use in Potentially Explosive Atmospheres (ATEX)

Notified Body for EU type Examination (Module B):	Dekra Certification B.V. Notified Body No.: 0344 Meander 1051, 6825 MJ Arnhem, The Netherlands
EU-type Examination Certificate (Module B):	KEMA 00ATEX2006X
Notified Body for Quality Assurance Notification / Conformity to EU-type based on quality assurance of the production process (Module D):	Sira Certification Service Notified Body No.: 0518 Rake Lane, Eccleston, Chester CH4 9JN, UK
Quality Assurance Notification (Module D):	SIRA 05 ATEX M342
Provisions fulfilled by the equipment:	II 2G Ex d IIC T4 to T6 Gb II 2D Ex tb IIIC T85°C to T125°C Db IP6X Dust Protection to EN60079-0 / EN60079-31
Standards applied:	EN 60079-0:2012 + A11:2013 EN 60079-1:2007 EN 60079-31:2014

## Directive 2014/30/EU: Electromagnetic Compatibility Directive (EMC)

Standards applied:	EN 61000-6-1:2007 EN 61000-6-2:2005 EN 61000-6-3:2007 / A1:2011 / AC: 2012 EN 61000-6-4:2007 / A1: 2011
--------------------	--

## Directive 2011/65/EU: Restriction of the use of certain hazardous substances in electrical and electronic equipment (RoHS)

The product and all the components contained within it are in accordance with the restriction of the use of hazardous substances in electrical and electronic equipment.

## Regulation (EC) 1907/2006: Registration, Evaluation, Authorisation and Restriction of Chemicals (REACH)

The product and all the components contained within it are free from substances of very high concern.

## Other Standards and Regulations

Safety Integrity Level:	suitable for <b>SIL2</b> (for product software and hardware)
System Capability:	suitable for <b>SC=2</b> (for product software and hardware)
System Capability assessment:	<b>1s</b> (by cross-functional team assessment)
IEC 61508-1 (2010) Functional safety of electrical/electronic/programmable electronic safety-related systems - Part 1: General requirements	
IEC 61508-2 (2010) Functional safety of electrical/electronic/programmable electronic safety-related systems - Part 2: Requirements for electrical/electronic/programmable electronic safety-related systems	
IEC 61508-3 (2010) Functional safety of electrical/electronic/programmable electronic safety-related systems - Part 3: Software requirements	
EN 60529:1991 + A1:2000 + A2:2013 - Degrees of protection provided by enclosures (IP code) – enclosure rated IP66/67	

---

On behalf of European Safety Systems Ltd., I declare that, on the date the equipment accompanied by this declaration is placed on the market, the equipment conforms with all technical and regulatory requirements of the above listed directives, regulations and standards.

This Declaration is issued under the sole responsibility of the manufacturer.

  
Martin Streetz  
Quality Assurance Manager

Document No.: DC-065\_Issue\_D  
Date and Place of Issue: London, 08/09/2016